

Big Smart Fans

High volume low speed fans



About Us



LTi Ventilatoren (Asia) Pte Ltd, established to support local market by producing complete range of fans with national/international technologies to serve our customers locally & globally.

Our experience in the ventilation systems give our customers confidence to have most efficient/economical solutions for their ventilation requirements. This confidence in LTi & its high quality products is backed by excellent pre/after sales services by our experienced sales & technical staff.

We provide complete solutions to ventilation problems arising from air & sound. With this catalogue of fans, we provide our customers the complete overview fan range LTi can offer to the market. For further detailed discussions &

information kindly feel free to contact our local sales company/distributor/dealer worldwide.

LTi Ventilatoren, we deal in indoor air quality (IAQ), an important ingredient of life from past 10 years. With the long history & experience of manufacturing of ventilation products with our colleagues having more than 30 years of experience, LTi Ventilatoren have been able to setup several production plants across the globe.

Our long experience & efforts we put into our R&D, we are successfully able to develop new innovative products with higher efficiencies & low noise levels.

Our name LTi, L-Long term T-Technical i-Innovative, supports our concept of continuous growth with our technical innovations on our existing product range & to develop new products for ever growing markets.

Our wide product range includes Axial fans, Bifurcated axial fans, belt driven axial fans, Jet fans, centrifugal fans, In-line fans, mixed flow fans, special application fans for chemical resistance & battery room applications. Our customers are in domestic sector, commercial sector, industries, power sector & infrastructure of ventilation market.

Quality standards

Our focus is customer satisfaction, which comes through with best quality & accurate deliveries. We believe in quality products. Our products have been tested & endorsed in Singapore by PSB (Productivity & standard board) & AMCA Singapore. All performances are in accordance to AMCA standards for air & sound. For high temperature fans we follow BS/EN standards for different temperatures & time classifications.

*No liability for errors! - Subject to technical modification

Our Projects



Project Title: ITE College & HQ @ AMK
 Consultant: Kajima
 Fan supplied : Axial, Cabinet & MIL



Project Title: The Estuary
 Contractor: Great Resources M&E Contractor Pte Ltd
 Fan supplied: Axial, Cabinet & CIL



Project Title: Suki Sushi
 Contractor: Natural Cool Airconditioning & Engineering Pte Ltd
 Fan supplied: Axial, Cabinet, CIL & Propeller



Project Title: Central Fire Station
 Contractor: BNF Engineering (S) Pte Ltd
 Fan supplied: CIL & Propeller

*Air Movement and Control
 Association International, Inc.*

Certifies that

LTI Ventilatoren (Asia) Pte Ltd

*Having satisfied the membership requirements, has been granted membership in the
 Air Movement and Control Association International, Inc.*

*Member Since
 February 2011*

 AMCA International President



 Acting Executive Director



Benefits of Big Smart Fans

Require lower cost for investment, installation and maintenance than traditional cooling methods.

- Cut energy consumption for cooling/heating. Provide eco-friendly and economic solutions.
- Assist in the removal of contaminant and heat.
- Help to reduce condensation on floors and equipments.
- Work coordinated with high velocity fans and other air conditioning systems.
- Offer multi-fan control and adjustable fan speed.
- Offer silent operation. Supply winter destratification and summer cooling.

Recommended Applications

- **Large Buildings with High Ceilings**
(Fair Exhibition Centers, Malls, Shopping Centers, Showrooms, Sports Halls)
- **Places Where Maximum Air Movement is Required**
(Warehouses, Factories, Aircraft Hangars, Poultry Houses, Farms, Animal Husbandry Facilities)
- **Busy Places Where People Come Together**
(Entertaining Centers, Cafeterias, Libraries, Museums, Theater, Opera, Concert Halls)

Mounting & Details

- Mounting service and custom mounting systems for customers.
- Fan can be mounted to I-beam or angle iron, for vertical installations w/o ceiling support.
- Safety cable secures the fan to the mounting structure.
- Fans are tested and simulated for best results.

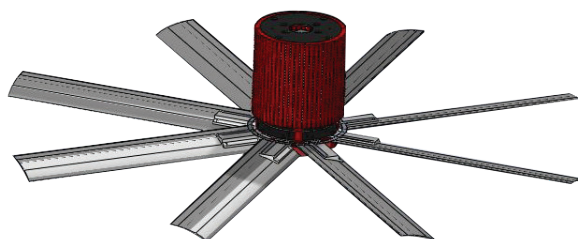

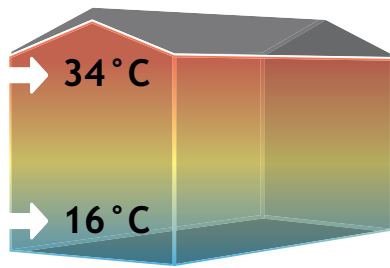

Before Ceiling Fan

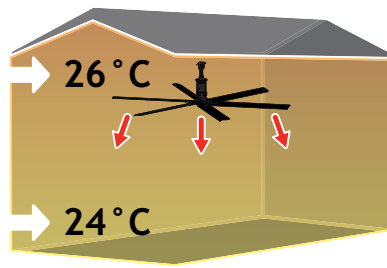

After Ceiling Fan

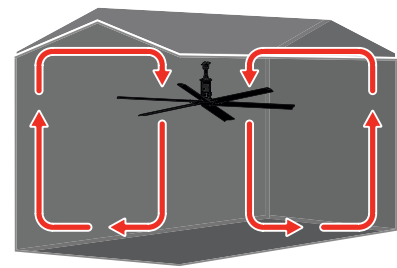

Airflow in an Enclosed Area

Winter Destratification

- Cut energy consumption for heating. Provide eco-friendly and economic solutions.
- Bring heated air at the ceiling down to the floor. Supply warm air destratification

Body conducts heat into the air layer.

- The real feel temperature is consideration of temperature, air movement and dew point.
- Air movement doesn't affect temperature but makes feel cooler by removing body heat.

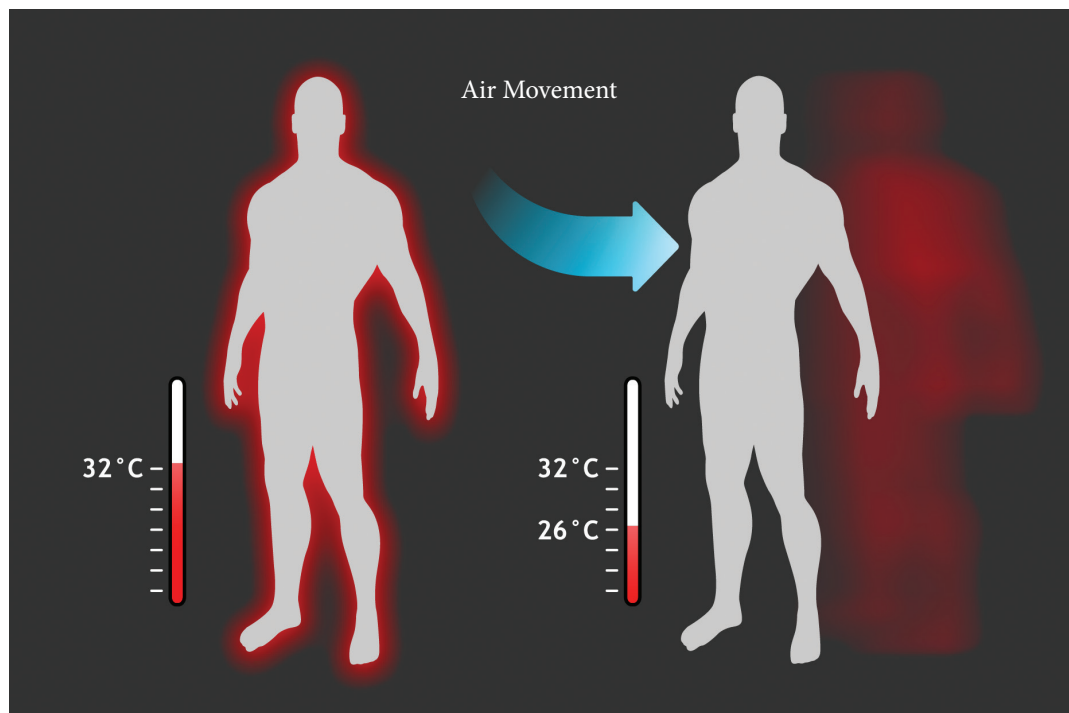

Body conducts heat into the air layer.

Cooling with air movement.

Summer Cooling

- Require lower cost for investment, installation and maintenance than traditional cooling methods.
- Improve worker comfort, enhance productivity with minimum energy consumption.

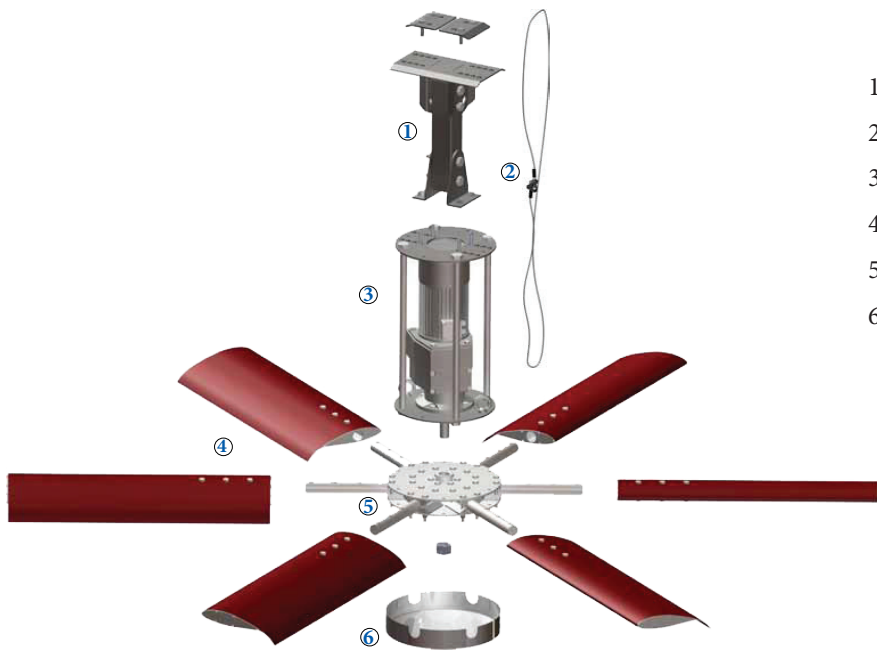

- 1 Single Pivot Adjustable Mount
- 2 Secure Safety Cable
- 3 Gear Reduction Motor
- 4 Fan Blades
- 5 Fan Hub
- 6 Bottom Cover

Dimensions

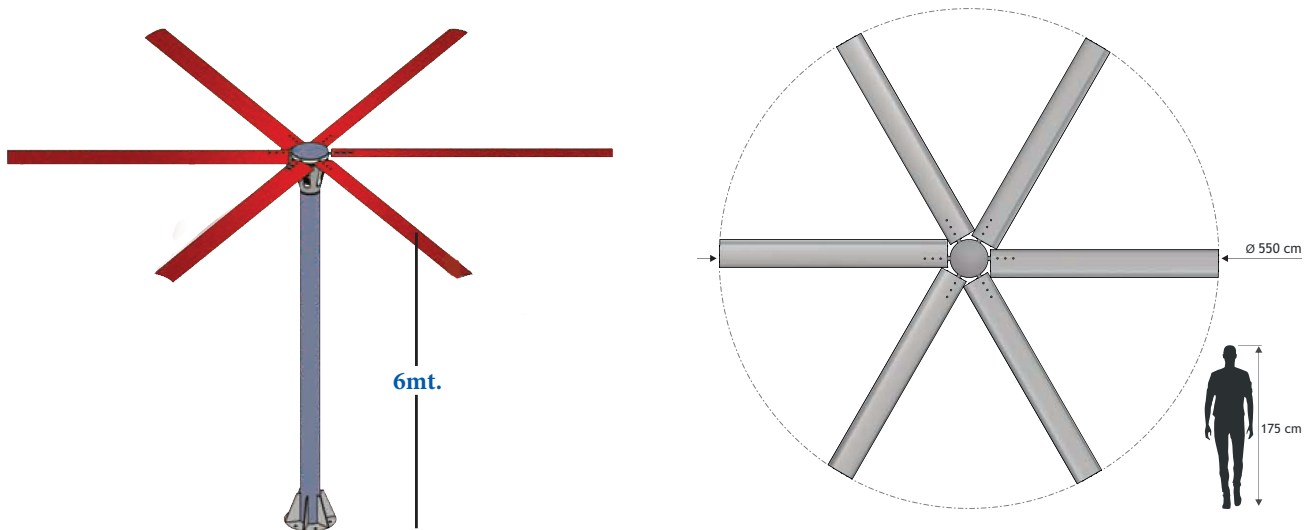
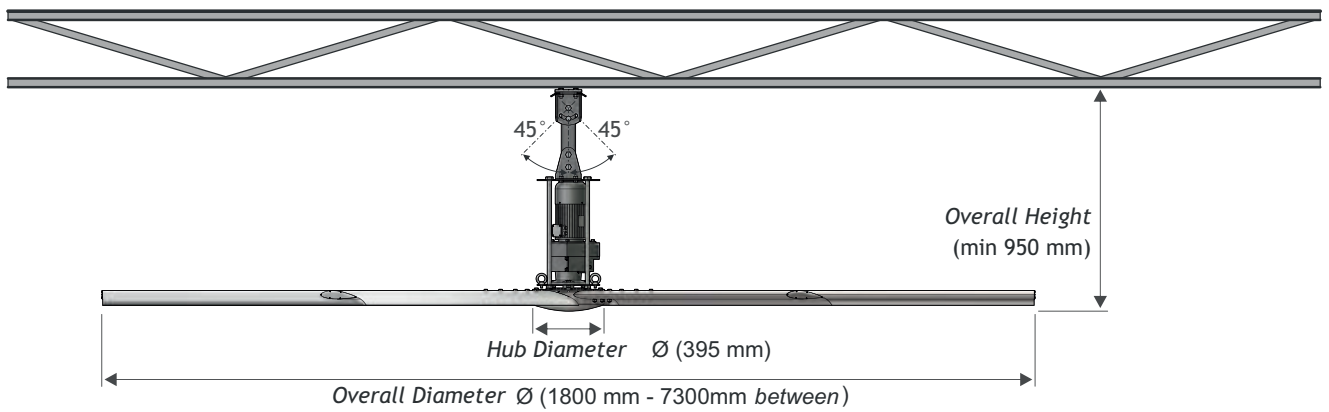

Technical Specifications

Model	Diameter Ø	Motor	Air flow	Coverage Area	Speed (RPM)	Weight (kg)
BSF2500	2500mm	1.1 KW	29 m ³ /s	370 m ²	150-160	105
BSF3000	3000mm	1.1 KW	38 m ³ /s	520 m ²	90-100	110
BSF3500	3500mm	1.1 KW	53 m ³ /s	650 m ²	90-100	113
BSF4000	4000mm	1.5 KW	60 m ³ /s	740 m ²	80-90	116
BSF4500	4500mm	1.5 KW	69 m ³ /s	1050 m ²	60-70	120
BSF5000	5000mm	1.5 KW	81 m ³ /s	1300 m ²	60-70	125
BSF5500	5500mm	2.2 KW	90 m ³ /s	1420 m ²	50-60	128
BSF6500	6500mm	2.2 KW	135 m ³ /s	1600 m ²	50-60	135
BSF7300	7300mm	2.2 KW	160 m ³ /s	1750 m ²	40-50	184

Model	Diameter Ø	Pole Length	Motor	Air flow	Coverage Area	Speed (RPM)	Weight (kg)
BSFP2500	2500mm	3000mm	0.75 KW	32 m ³ /s	390 m ²	max. 188	178
BSFP3000	3000mm	4000mm	1.1 KW	38 m ³ /s	520 m ²	max. 94	206
BSFP3500	3500mm	4000mm	1.1 KW	53 m ³ /s	650 m ²	max. 94	210
BSFP4000	4000mm	5000mm	1.1 KW	60 m ³ /s	740 m ²	max. 94	251
BSFP4500	4500mm	5000mm	1.5 KW	69 m ³ /s	900 m ²	max. 61	255
BSFP5100	5100mm	6000mm	1.5 KW	81 m ³ /s	1250 m ²	max. 61	291
BSFP5500	5500mm	6000mm	2.2 KW	90 m ³ /s	1420 m ²	max. 61	293
BSFP6500	6500mm	6100mm	2.2 KW	135 m ³ /s	1600 m ²	max. 65	306
BSFP7300	7300mm	7100mm	2.2 KW	160 m ³ /s	1750 m ²	max. 50	184

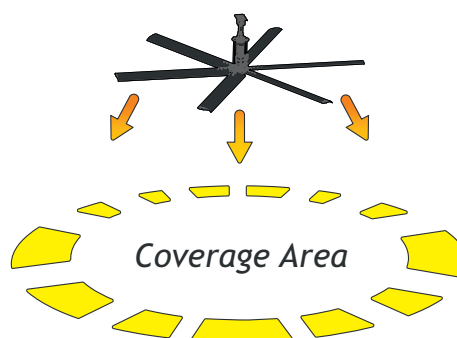

Fan Control Cabinet

- Supply voltage 220 volt (1 ~)
- Speed control Device (1 - 1.5 - 2.2 KW)
- Panel dimensions 300 x 400 x 170 mm
- IP 54 protected
- Motor supply volt. 400V (3~)
- Speed setting potentiometer
- Operating mode selector switch



Lti Ventilatoren (Asia) P/L
19, Jln Mesin. Singapore 368818

Tel. : +65 65646678
Fax : +65 65646166
mail : sale@lti.com.sg

*subject to technical modification

www.lti.com.sg